

Adding High Availability to Condor Matchmaker

Mark Silberstein, Gabi Kliot, Assaf Schuster
Technion – Israel Institute of Technology



Highly Available Matchmaker

- Matchmaker is a **single-point-of-failure**
 - Negotiator's failure - No additional matches will be possible
 - Collector's failure – negotiator is out of job, tools querying collector won't work, etc.
- Our goal
 - **Negligible throughput degradation** in case of failure



Highly Available Matchmaker

- Our solution - Highly Available Matchmaker
 - **Automatic** failure detection
 - **Transparent** failover to backup matchmaker (no global configuration change for the pool entities)
 - **State replication** between primary and backups
 - **“Split brain” reconciliation** after network partitions

How it works – Election

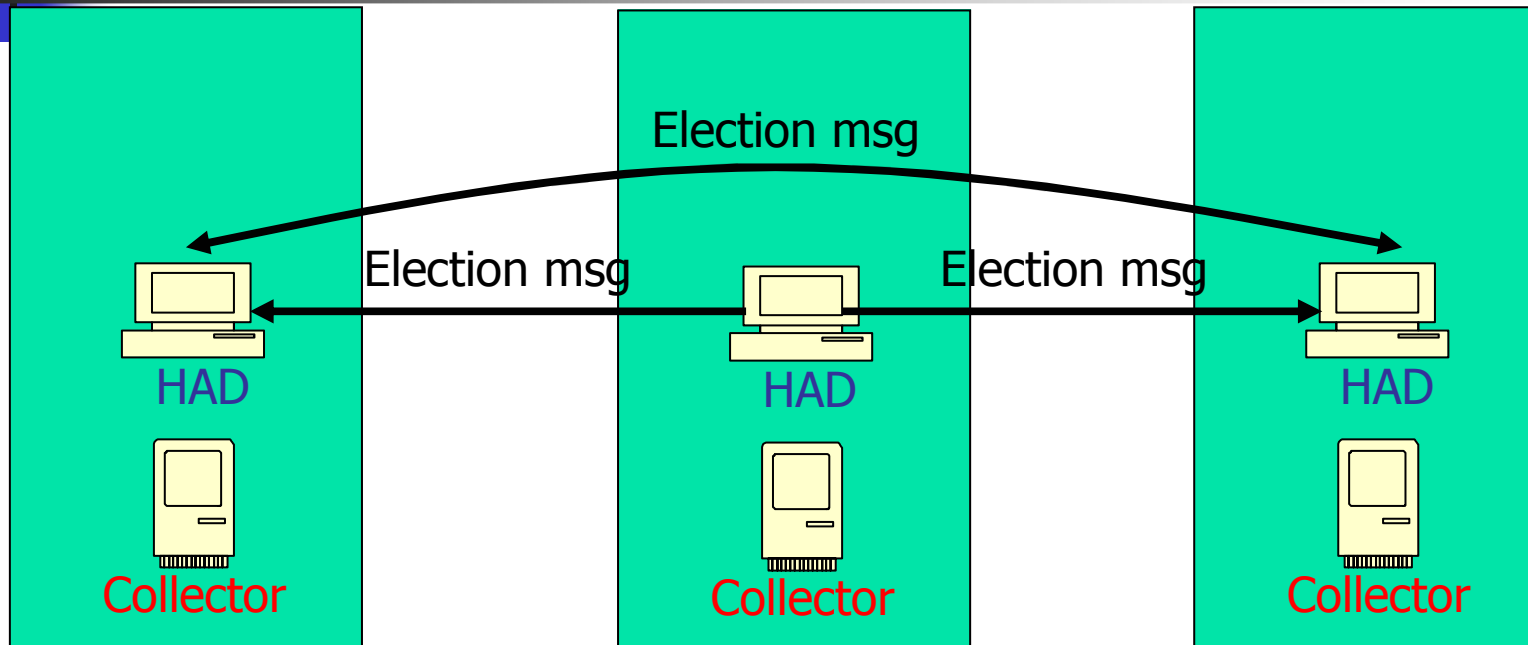

How it works – basic scenario

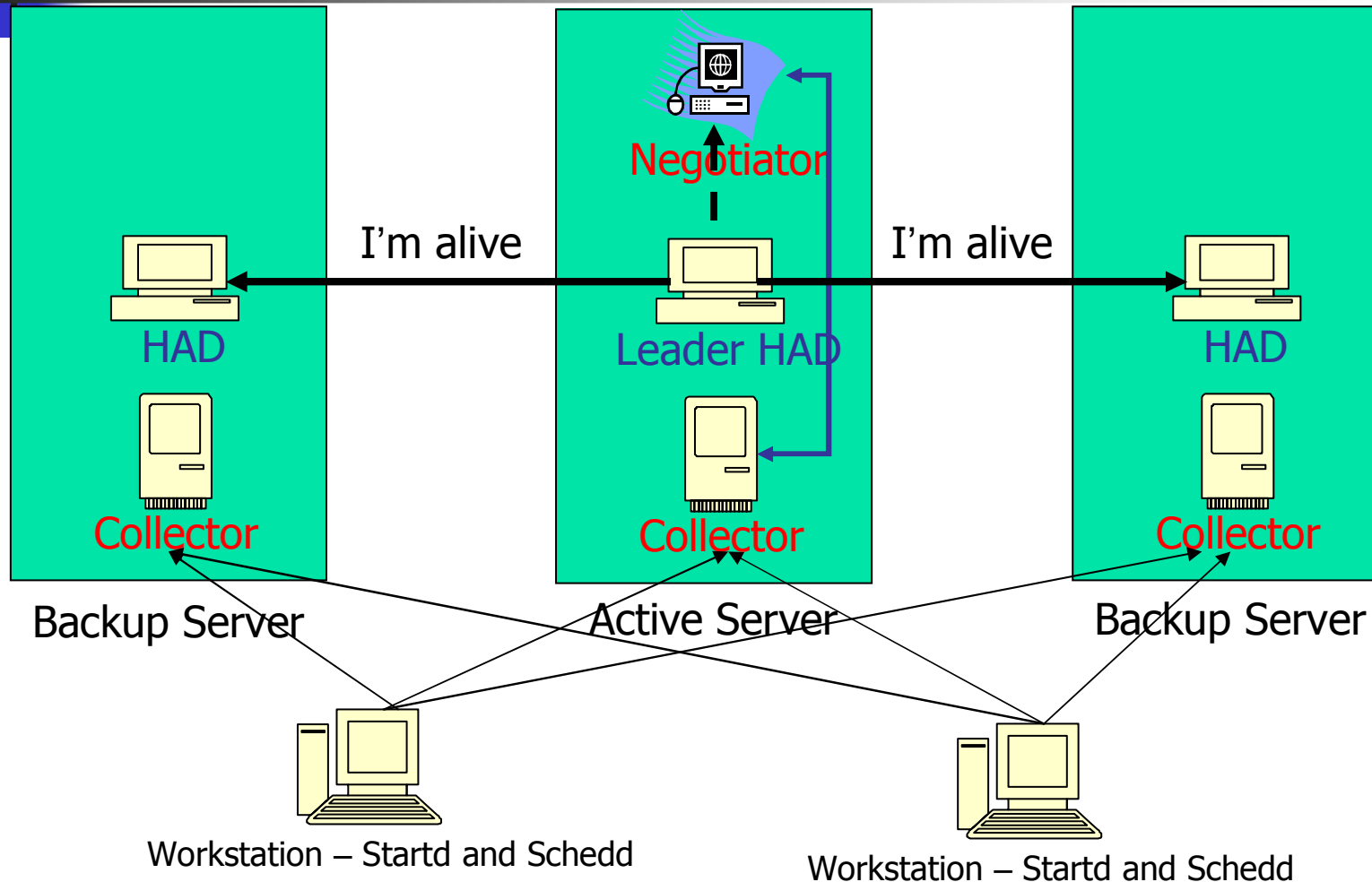

How it works – crash event

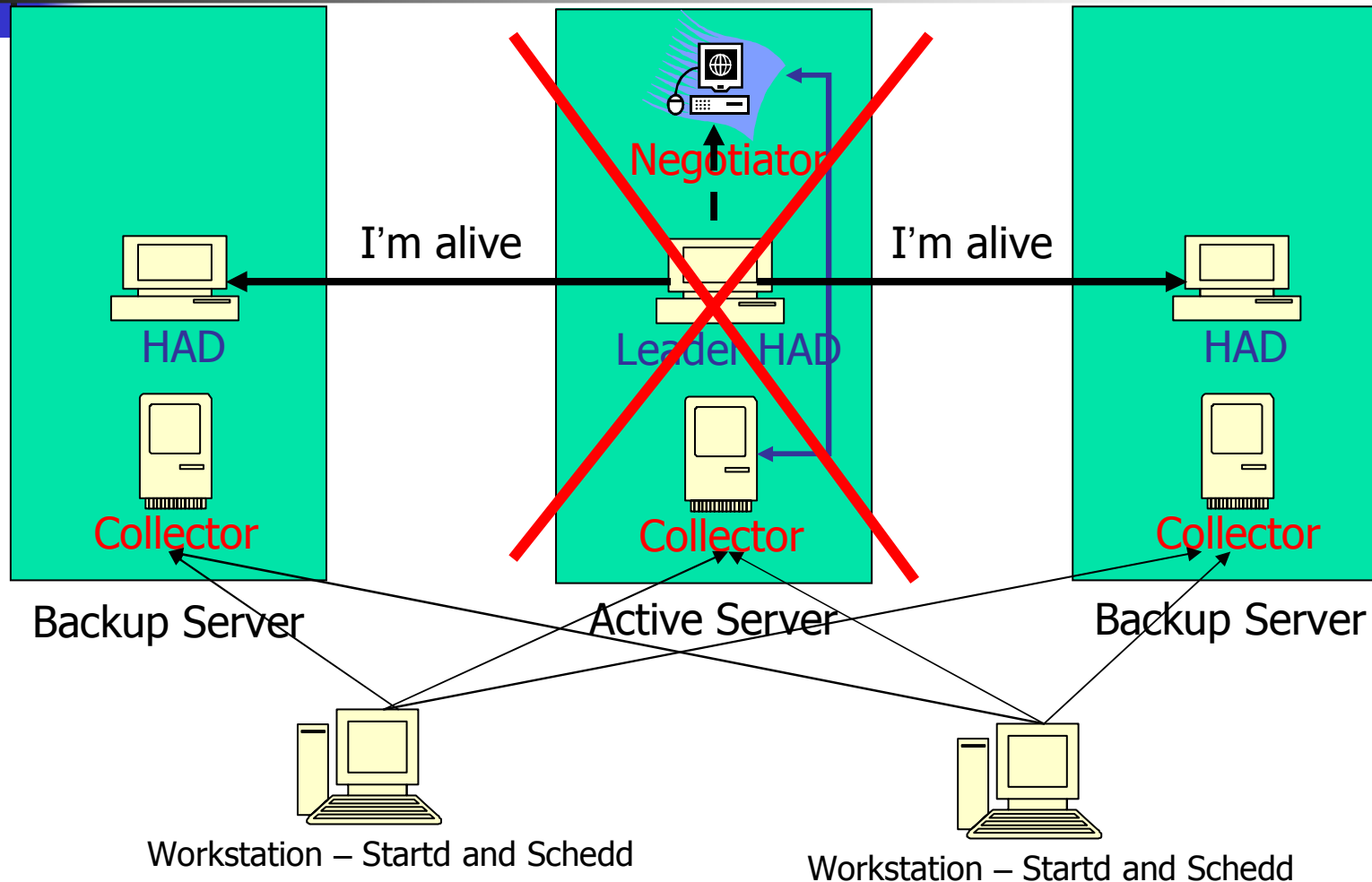

How it works – crash event

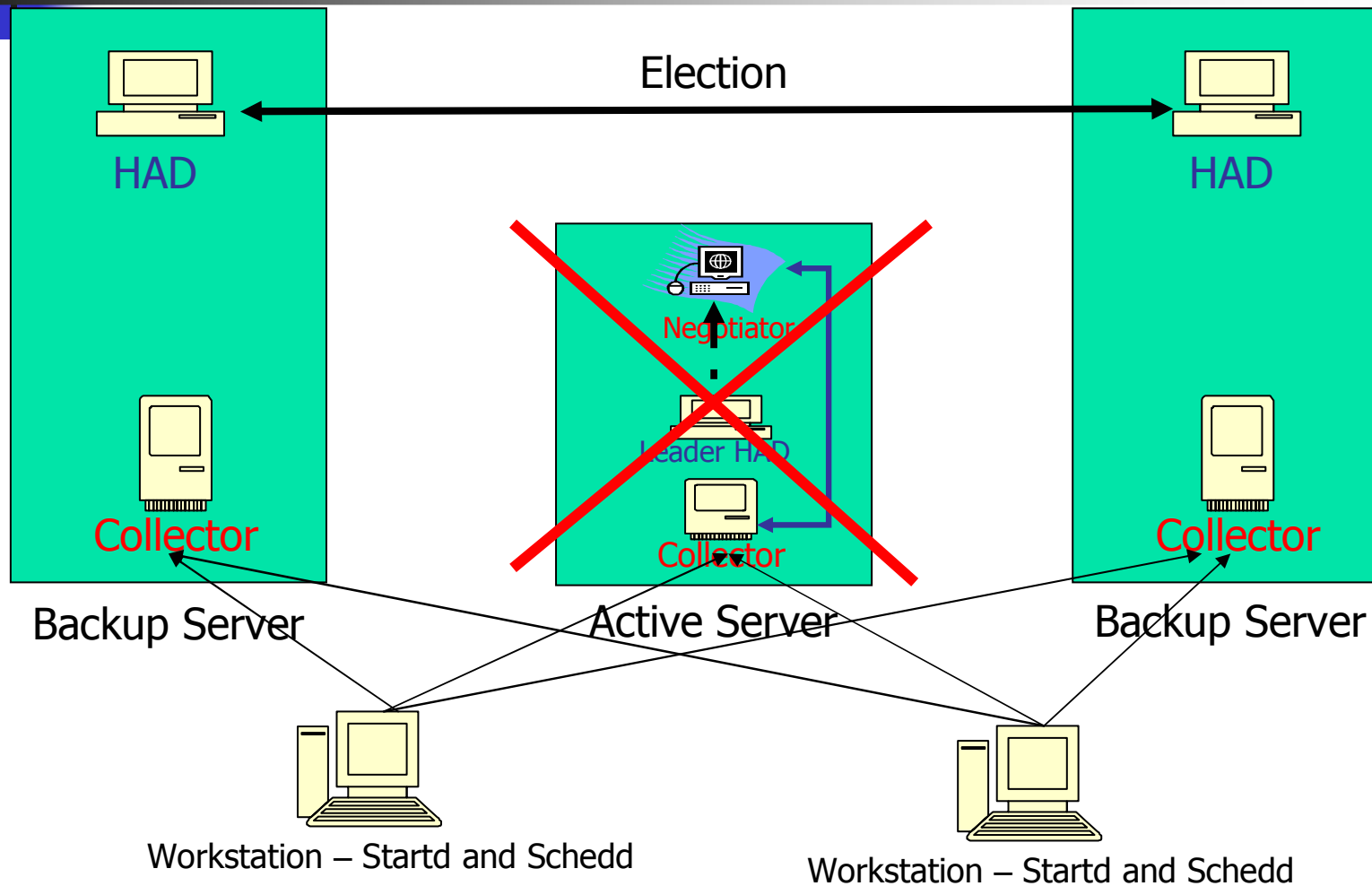

How it works – crash event

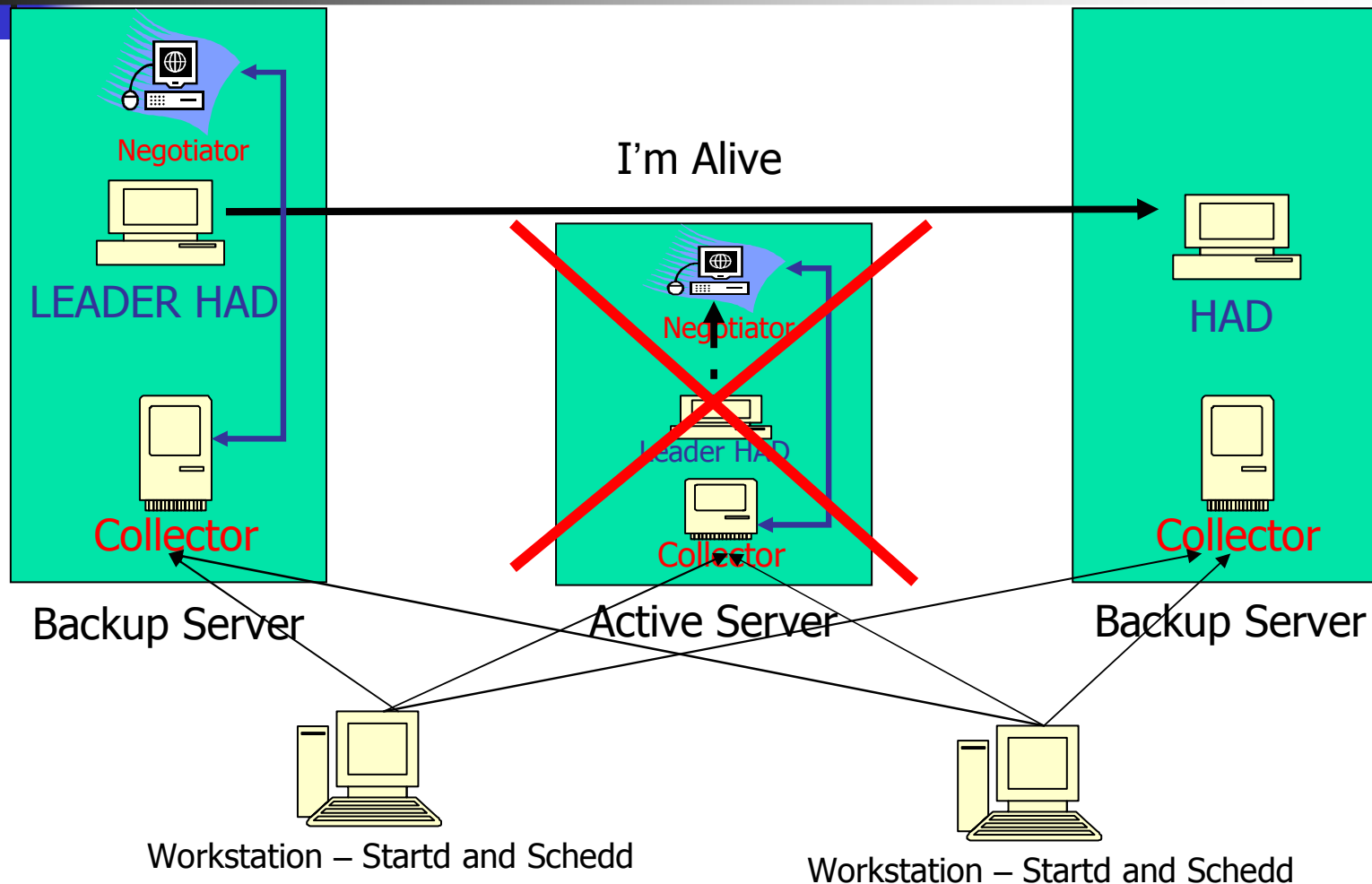

Status



- Prototype was released at April 2004
- Currently finished all implementation and in the advanced stages of debugging
- More information:
 - http://dsl.cs.technion.ac.il/projects/gozal/project_pages/ha/ha.html

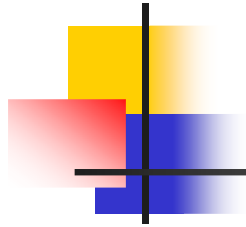

In case of time

High Availability Daemon State machine

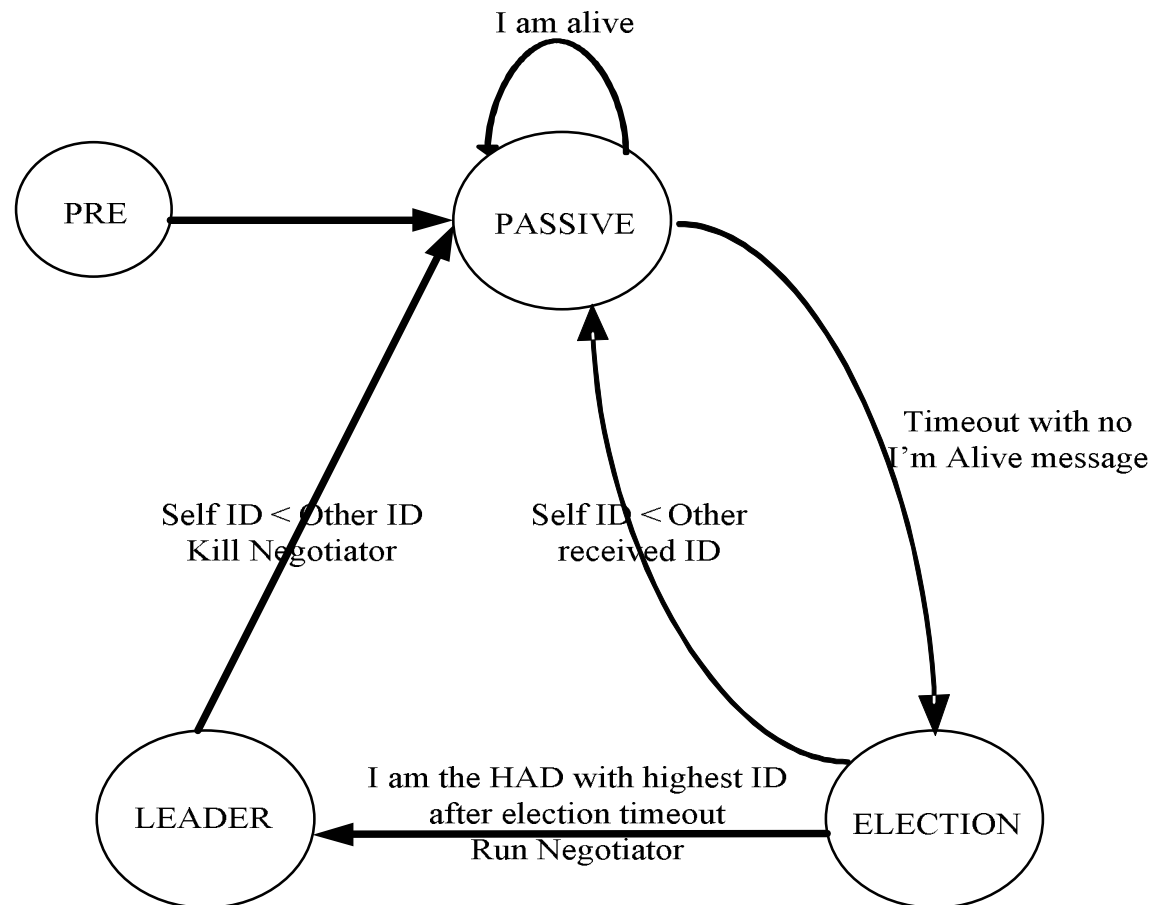

How it works – basic scenario

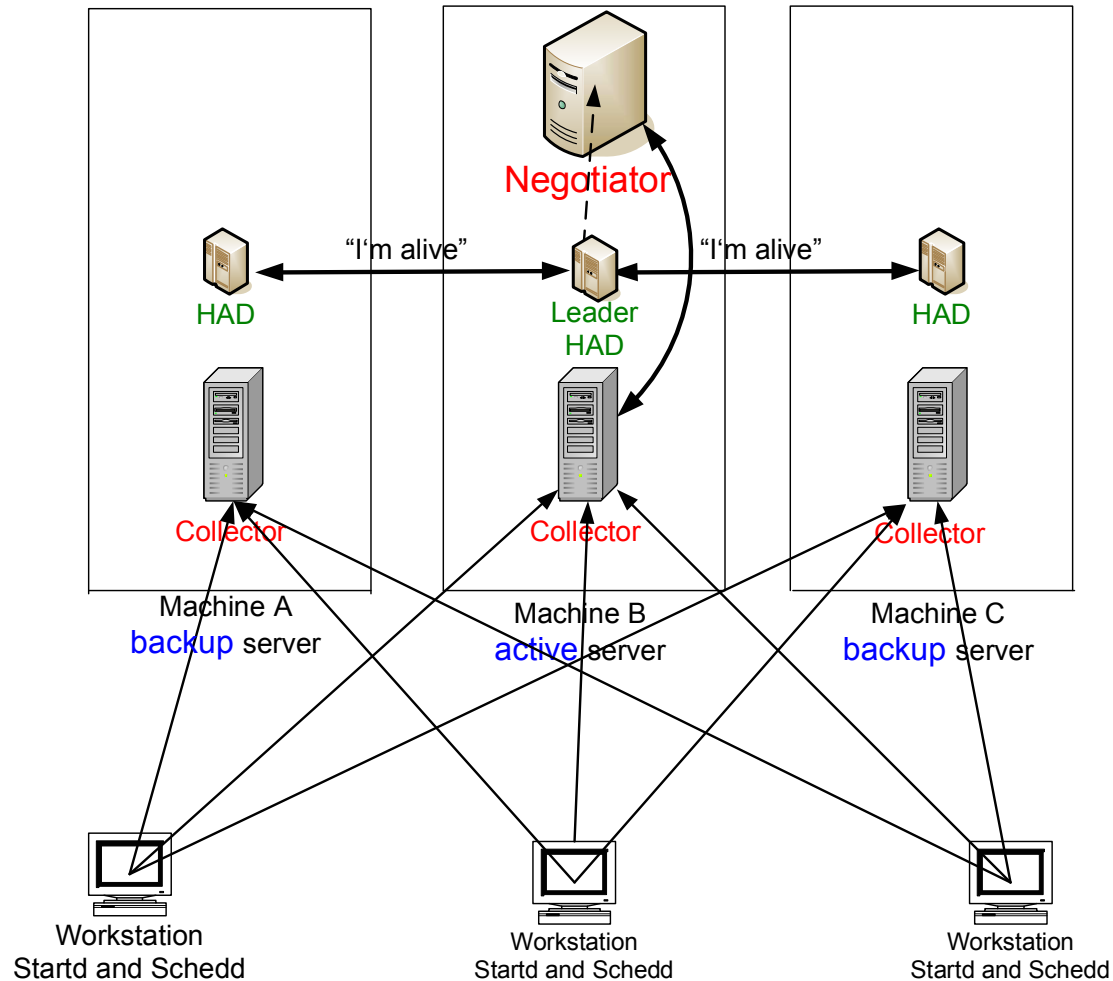

How it works – crash event

